

DEAN®

SR114E Super Runner Value Electric Fryer

Project _____
Item _____
Quantity _____
CSI Section 11400 _____
Approval _____
Date _____

Models

SR114E



SR114E
Shown with optional casters.

Standard Features

- 40-lb. (20 liter) frypot oil capacity
- 14 kw
- Frying area 13-3/4" x 13-3/4" x 5-1/4" (34.8 x 34.8 x 13.3 cm)
- Durable temperature probe
- Wide cold zone
- Stainless steel frypot, door and backsplash/flue cover with aluminized sides
- Basket hanger
- Two twin baskets
- Power switch and indicator light
- 6" (15 cm) steel legs with 1" adjustment
- Basket support rack

Options & Accessories

- Frypot cover
- Casters
- Full basket
- Top connecting strip

Specifications

Basic Frying At Its Best -- Designed For All-Purpose Affordable Frying

Fry a wide variety of products with the full-size frying area which easily accommodates items from appetizers to specialty foods -- chicken, fries and breaded products, fresh or frozen.

Make the most of your energy dollars with our fully submersed element package. Heat absorption is maximized by full contact with the oil, allowing quick heat-up time and lower

energy consumption per pound of product cooked.

Dean's wide cool zone design minimizes wasteful oil deterioration by trapping debris under the cooking area, preventing carbonization of particles and oil contamination. The sloped bottom permits fast, easy draining of oil and sediment.

Assure rapid recovery with Dean's durable temperature probe which reacts quickly to changes in load conditions and helps eliminate loss of time incurred waiting between loads.



8700 Line Avenue
Shreveport, LA 71106-6800
USA

Tel: 318-865-1711
Tel: 1-800-221-4583
E-mail: info@frymaster.com

www.frymaster.com
7388A_SR114E
09/21



SR114E Super Runner Value Electric Fryer

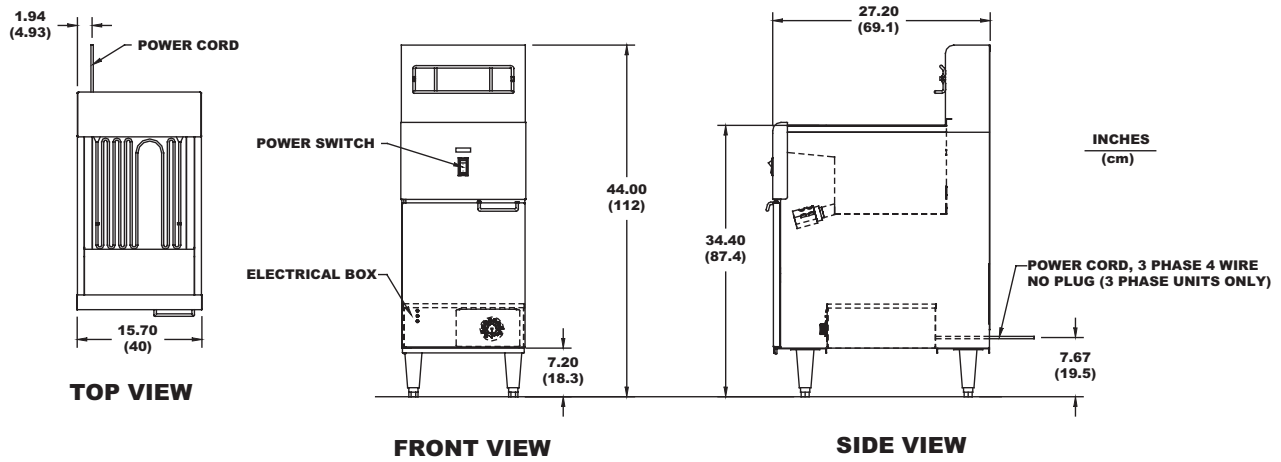

DIMENSIONS

MODEL	OIL CAPACITY	OVERALL SIZE (cm)			DRAIN HEIGHT (cm)	APPROXIMATE SHIPPING DIMENSIONS					
		WIDTH	DEPTH	HEIGHT		WEIGHT	CLASS	CU. FT.	DIMENSIONS (cm)		
SR114E	40 lb. (20 liter)	15-3/4" (40)	27-1/4" (69.1)	44" (112)	23" (58.4)	180 lbs. (82 kg)	85	21	W 20-1/2" (52)	D 36" (91)	H 48-1/2" (123)

POWER REQUIREMENTS

BASIC DOMESTIC	kw	ELEMENTS/FRYPOT		
		VOLTAGE	3 PHASE*	1 PHASE**
SR114E	14	208V 240V	39 A 34 A	68 A 59 A
BASIC EXPORT	kw			
SR114E	14	220V 230V/400V	37 A 21 A	64 A N/A

*3 PH/3 Wire/Plus Ground Wire
 **1 PH/2 Wire/Plus Ground Wire

NOTE:

- 3-phase units with cord only -- no plug provided.
- 1-phase units to be field wired, no cord or plug provided.
- All Canadian and single phase units sold without cordset.

HOW TO SPECIFY

The following description will assist with ordering the features desired for this equipment:

SR114E 40-lb. (20-liter) oil capacity, 14 kw electric fryer with power switch and indicator light.

Welbilt reserves the right to make changes to the design or specifications without prior notice.

8700 Line Avenue
 Shreveport, LA 71106-6800
 USA

Tel: 318-865-1711
 Tel: 1-800-221-4583
 E-mail: info@frymaster.com

www.frymaster.com
 7388A_SR114E
 09/21

