



## Features

### IoT Connectivity

Connection and integration with POS and KMS networks

### All-Day Menu Variety

Up to six different daypart menu options

### Dual Zone Temperature Control

Zoned top and bottom heaters control temperatures for every two pans to better manage food quality

### Digital Display

Digital display front and back timer bars available

### Durable Construction

Durable stainless steel construction for longer lasting equipment life

### Cook More Alert

Never run out of food with alerts that notify when to cook more product

### Single-Sided and Pass-Through Design

Configurations available in single-sided and pass-through design for maximum application flexibility

### Simple Menu Selection and Upload

USB port included for easy upload of new menus

### Rackless Design

Fewer parts to clean and maintain simplifying the overall cleaning process

### Warranty

1-year parts and labor warranty including on-site service

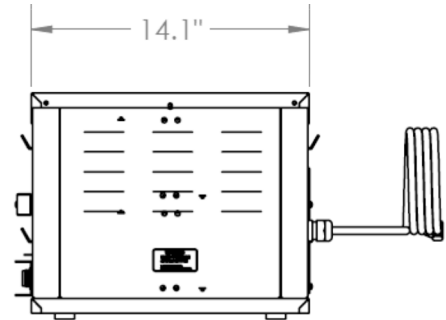
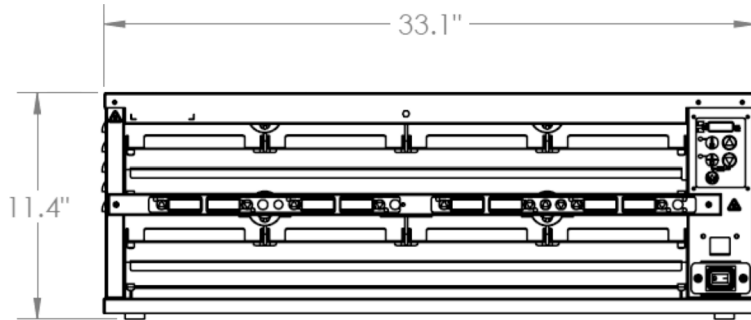

Model Number	Description
EHB24	EHB24, 1/3 Pan, Single Sided Timer Bar, North America
EHB24A	EHB24, 1/3 Pan, Double Sided Timer Bar, North America
EHB24CE	EHB24, 1/3 Pan, Single Sided Timer Bar, International
EHB24ACE	EHB24, 1/3 Pan, Double Sided Timer Bar, International

Lid Count: EHB24 models come with 6 lids

Accessories Number	Description
TBD	1/3 Size x 2.5" Single Handle Pan
TBD	1/3 Size x 2.5" Dual Handle Pan
115-00242-16	Stainless Steel Trivet (Pack of 16)
540-1327S	PHU 2.5" Leg Kit

Burger King Corporation is requesting each store location have at least 32 PHU slots and Stainless Steel trivets for fried products - Stainless Steel trivets and plastic pans are sold separately.

## Technical Specifications

MODEL NUMBER	Width (cm)	Depth (cm)	Height (cm)	Weight (kg)	Shipping (kg)
EHB24	33.2" (84.3cm)	14.1" (35.8cm)	11.1" (28.2cm)	55 lbs (25 kg)	97 lbs (44 kg)
EHB24A	33.2" (84.3cm)	14.1" (35.8cm)	11.1" (28.2cm)	55 lbs (25 kg)	97 lbs (44 kg)
EHB24CE	33.2" (84.3cm)	14.1" (35.8cm)	11.1" (28.2cm)	55 lbs (25 kg)	97 lbs (44 kg)
EHB24ACE	33.2" (84.3cm)	14.1" (35.8cm)	11.1" (28.2cm)	55 lbs (25 kg)	97 lbs (44 kg)

MODEL NUMBER	Volts	Watts	Amps	Hertz	Plug
EHB24	208-240VAC	1792-2632	9.0-10.4	50/60	6-15P
EHB24A	208-240VAC	1792-2632	9.0-10.4	50/60	6-15P
EHB24CE	208-240VAC	1792-2632	9.0-10.4	50/60	IEC309
EHB24ACE	208-240VAC	1792-2632	9.0-10.4	50/60	IEC309

To learn more about **EHB Holding Bins** visit [princecastle.com](http://princecastle.com)  
 To contact a Prince Castle expert today, visit [princecastle.com/contact-us](http://princecastle.com/contact-us)