

TSSU-48-08-HC

 Prep Table, 8x 1/6 Top Pans, 2 Solid Swing Doors



| Dimensions | | Build | | Technical | |
|------------------------------------|--|-----------------------|---|-----------------------------|--------------------|
| External Width (mm) | 1229 | Door Description | 2 Solid Swing Doors | Temperature Holding | 0.5 : 5°C |
| External Depth (mm) | 766 | Exterior Construction | Stainless steel front, top & hood, aluminium sides and rear | Refrigerant | R290 |
| External Height (mm) | 1093 | Interior Construction | Clear coated aluminium, stainless steel base | Voltage / Frequency / Phase | 220-240V/50-60Hz/1 |
| Exclusions | Depth does not include 26 mm for rear bumpers. Height with lid closed. | Air Intake Position | Front | Amps | 2.3 |
| Gross Volume (Litres) | 340 | Ventilation Position | Front | Wattage | 529 |
| Supplied Shelves | 4 | Clearance Required | Zero back and sides | Defrost Type | Auto |
| Shelf Size (L x D mm) | Two 547 x 514 + Two 547 x 349 | Cord Length (Meters) | 3.35 | | |
| Internal Net Height (mm) | 535 | Standard w/ Locks | Not standard (SPEC3 option) | | |
| Top Pans Supplied (depth mm) | 8x 1/6 GN (100) | | | | |
| Unpackaged Weight (kg) | 123 | | | | |
| Packaged Weight (kg) | 134 | | | | |
| Packaged Dimensions (W x D x H mm) | 1302 x 833 x 1270 | | | | |
| Cutting Board (L x D mm) | 1229 x 299 | | | | |
| Supplied with | ø 127 mm castors (158 mm height) | | | | |



Specifications subject to change without notice.
Chart dimensions rounded up to the next whole millimeter (inches rounded up to the 1/8")

UK & Ireland [0800 783 2049](tel:08007832049)
EMEA [+41 61 563 07 05](tel:+41615630705)
Australia [+61 2 9619 9999](tel:+61296199999)

TFIUK@truemfg.com
TrueCHCustomerService@truemfg.com
TrueRefAus@truemfg.com



TSSU-48-08-HC

🇬🇧 Prep Table, 8x 1/6 Top Pans, 2 Solid Swing Doors

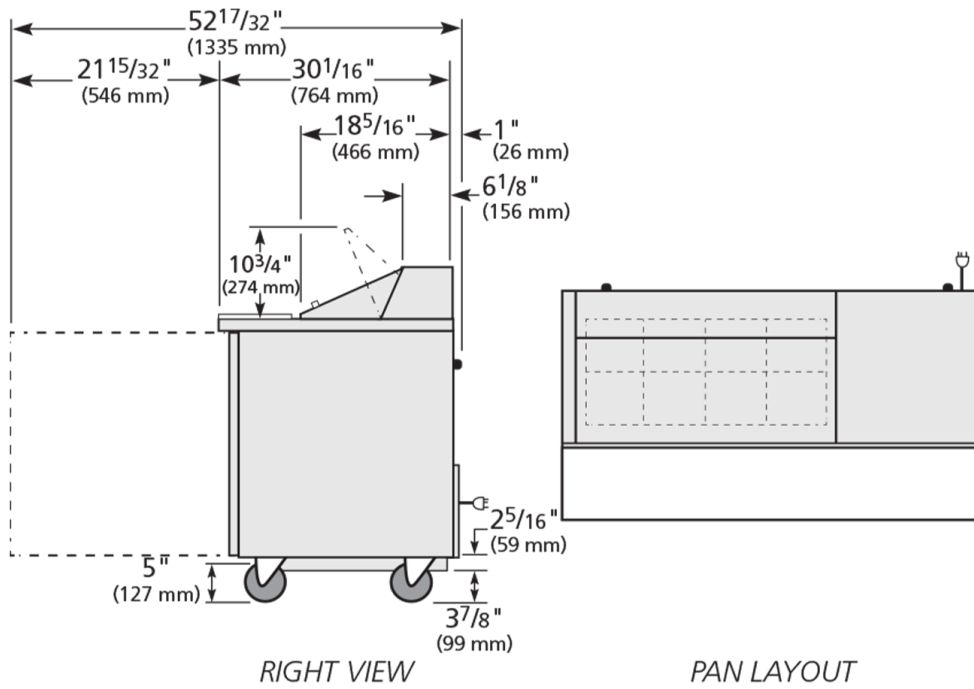
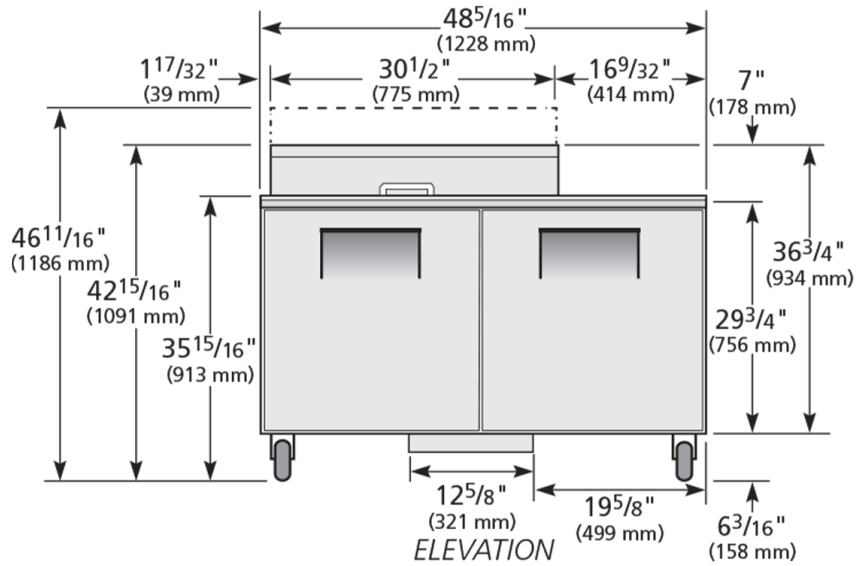

Specifications subject to change without notice.
Chart dimensions rounded up to the next whole millimeter (inches rounded up to the 1/8")

UK & Ireland [0800 783 2049](tel:08007832049)
 EMEA [+41 61 563 07 05](tel:+41615630705)
 Australia [+61 2 9619 9999](tel:+61296199999)

TFIUK@truemfg.com
TrueCHCustomerService@truemfg.com
TrueRefAus@truemfg.com

