

Glass Door Display

GDM-23F-HC~TSL01

 Upright Retail Merchandiser Freezer, 1 Full Glass Swing Door



| Dimensions | | Build | | Technical | |
|------------------------------------|--|-----------------------|--|-----------------------------|---|
| External Width (mm) | 686 | Door Description | 1 Full Glass Swing Door | Temperature Holding | -23°C |
| External Depth (mm) | 759 | Door Opening | Right (standard) or Left. | Refrigerant | R290 |
| External Height (mm) | 1998 | Exterior Construction | Black powder coated Stainless Steel front, matching Aluminium sides and rear | Voltage / Frequency / Phase | 220-240V/50Hz/1 |
| Exclusions | Depth does not include 42 mm for door handle or 13 mm for rear access panel. | Interior Construction | White coated aluminium, stainless steel base | Amps | 3.1 |
| Net Volume (Litres) | 445 | Air Intake Position | Front | Wattage | 713 |
| Gross Volume (Litres) | 651 | Ventilation Position | Rear | Temperature Class | L1 |
| Display Area (m ²) | 0.75 | Clearance Required | 26 mm rear, zero sides | Operating Statement | Tested at 25°C, 60% RH, per 'Refrigerators with a Direct Sales Function' for perishable food merchandising. |
| Supplied Shelves | 4 | Cord Length (Meters) | 2.74 | Testing Standard | EN 23953 |
| Shelf Size (L x D mm) | 574 x 591 | Internal Lighting | LED | EEC | C |
| Internal Net Height (mm) | 1300 | Standard w/ Locks | Not Standard. Options available. | EEl | 26.8 |
| Unpackaged Weight (kg) | 151 | | | kWh/24hr | 6.45 |
| Packaged Weight (kg) | 162 | | | kWh/Annum | 2355 |
| Packaged Dimensions (W x D x H mm) | 902 x 775 x 2134 | | | Defrost Type | Auto |
| Supplied with | Product supplied with Levelling Screws. Optional castors sold separately. | | | | |



Specifications subject to change without notice.
Chart dimensions rounded up to the next whole millimeter (inches rounded up to the 1/8")

UK & Ireland [0800 783 2049](tel:08007832049)
EMEA [+41 61 563 07 05](tel:+41615630705)
Australia [+61 2 9619 9999](tel:+61296199999)

TFIUK@truemfg.com
TrueCHCustomerService@truemfg.com
TrueRefAus@truemfg.com



GDM-23F-HC~TSL01

🇬🇧 Upright Retail Merchandiser Freezer, 1 Full Glass Swing Door

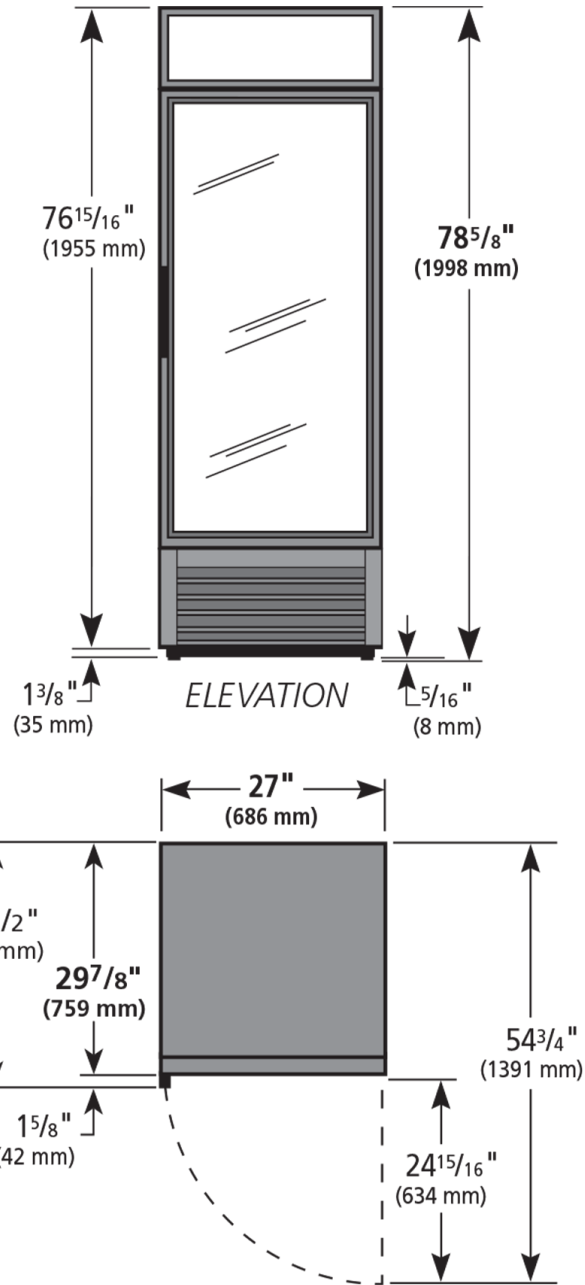

Specifications subject to change without notice.
Chart dimensions rounded up to the next whole millimeter (inches rounded up to the 1/8")

UK & Ireland 0800 783 2049
EMEA +41 61 563 07 05
Australia +61 2 9619 9999

TFIUK@truemfg.com
TrueCHCustomerService@truemfg.com
TrueRefAus@truemfg.com

